

# Jet

# KINGGATES

**Gear motor for swing gates**



# 1 - GENERAL DESCRIPTION

## 1A - WARNINGS

Unfulfilment of the below listed instructions will release the KING gates srl, from any responsibility for damage caused to people or things.

- Do not modify the product in any part.
- To optimize the functioning of the automation use KING gates accessories only.
- Installing, testing and first functioning have to observe the laws in force.
- The gear-motor doesn't require any maintenance because provided with a permanent lubrication system.
- Disposal of waste material has to observe local regulations.

## 1B - AVAILABLE VERSIONS

### AVAILABLE VERSIONS

Code	Motor	Mechanical stop	Fixing kit	Protective brushes	Wing max dimensions
Jet 230 F	230 Vac	• (1)	•		3 m; 600 kg
Jet 230 S	230 Vac	• (1)	•		3 m; 600 kg
Jet 24	24 Vdc	• (1)	•		3 m; 600 kg
Jet 230 F TOP	230 Vac	• (2)	•	•	3 m; 600 kg
Jet 230 S TOP	230 Vac	• (2)	•	•	3 m; 600 kg
Jet 24 TOP	24 Vdc	• (2)	•	•	3 m; 600 kg

### JET – TECHNICAL DATA

Code		JET 230 F (Top)	JET 230 S (Top)	JET 24 (Top)
Power supply	(Vac 50 Hz)	230		
Motor power supply	(Vac/Vdc)	230		24
Motor power	(W)	200	170	50
Speed	(m/sec)	0,016	0,01	0,013 ÷ 0,016
Journey	(mm)	360 (300)		
Protection level	(IP)	44		
Motor weight	(kg)	8		7
Max length of the gate	(m)	3		
Max weight of the gate	(kg)	600		
Work cycle	(%)	30		90
Motor dimensions	(mm)	100x110x820		
Working temperature	(°C)	-20 ÷ +55		

## 2 - TYPICAL SYSTEM

### 2A - TYPICAL SYSTEM

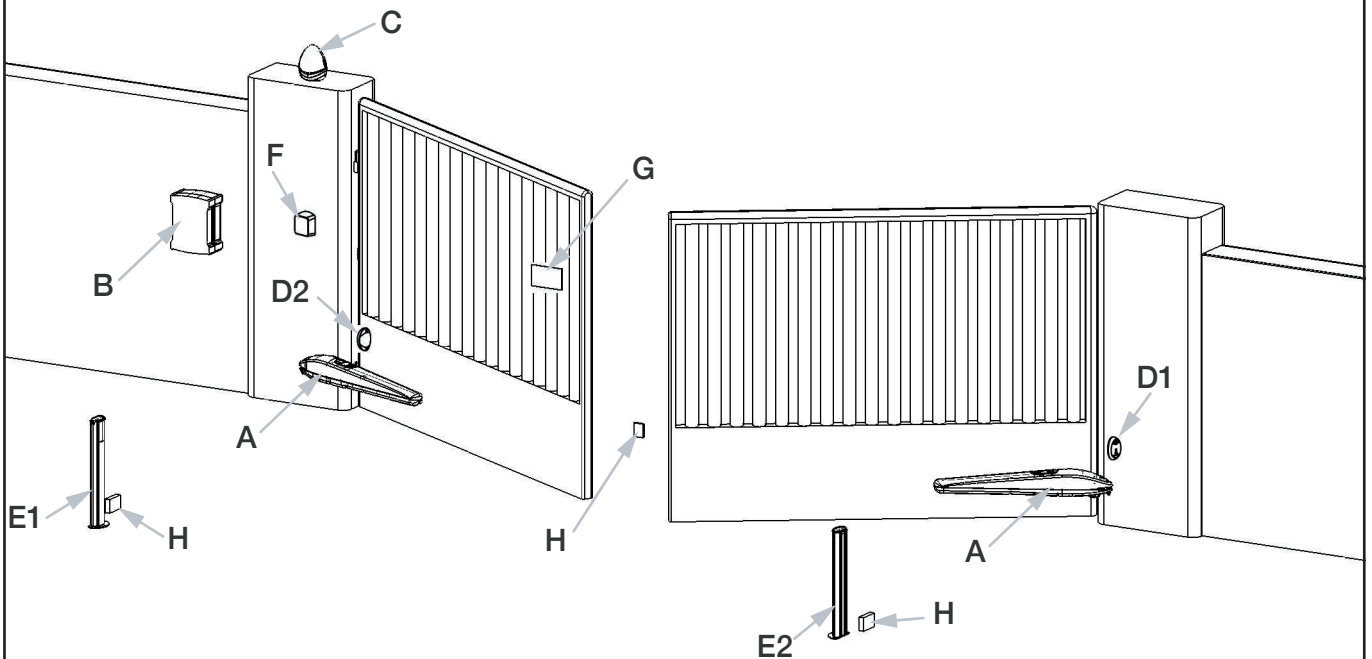

- A - Gear-motor
- B - Control unit
- C - Flashing-light with antenna
- D - Photocells (while closing)
- E - Photocells (while opening)
- F - Key selector
- G - Warning sign
- H - Stop locks

### 2B - TYPICAL CONNECTION AND CABLE SECTION

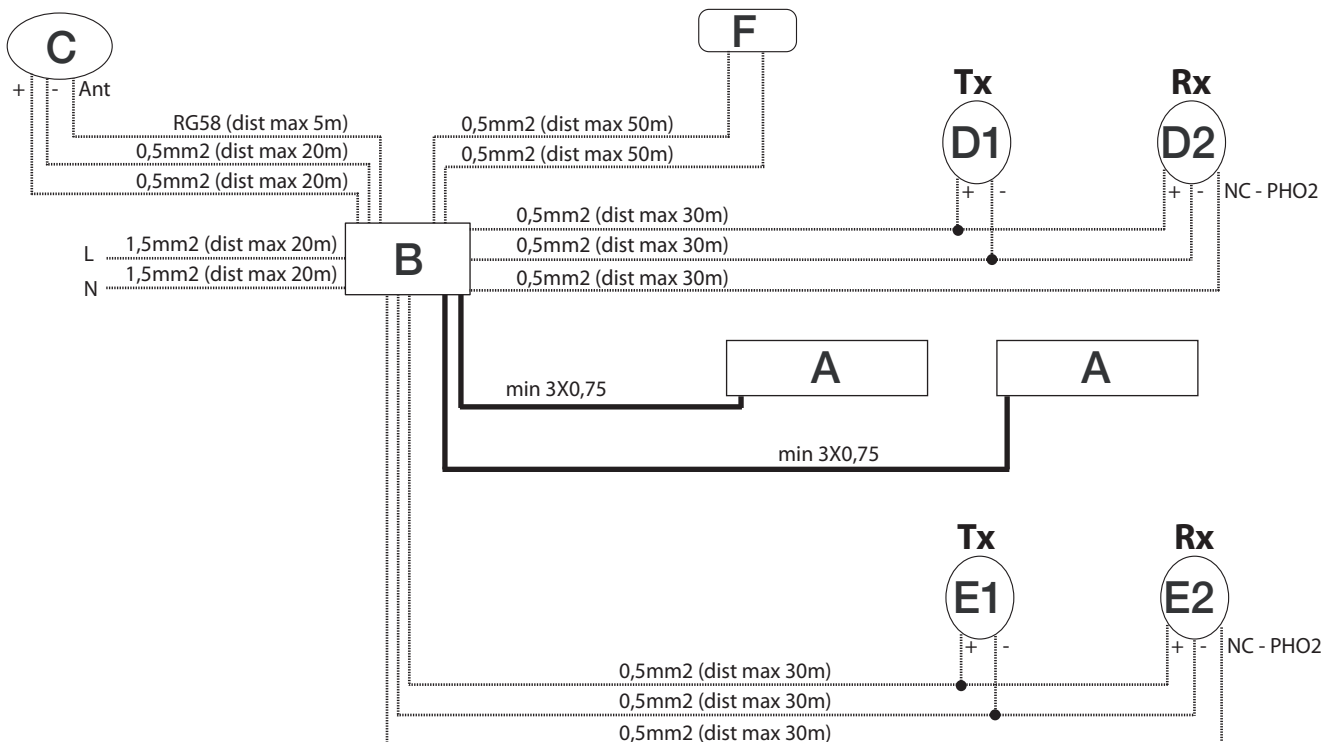

**2C - DIMENSIONS**

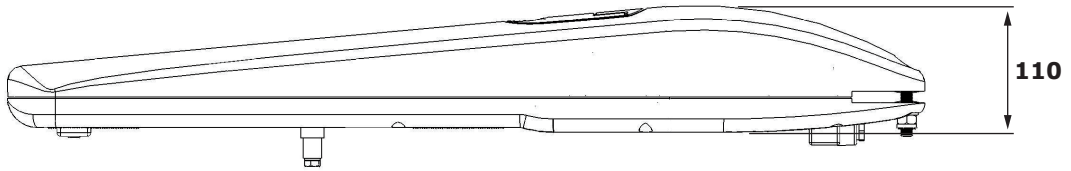
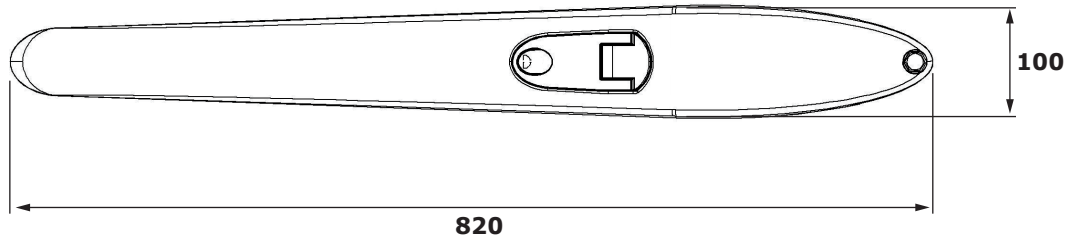

**Front  
braket**

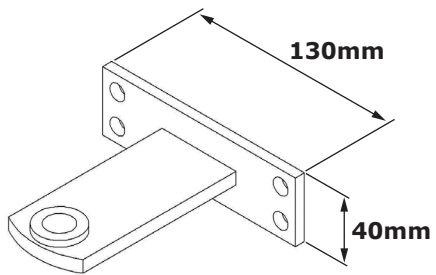

**Rear  
braket**

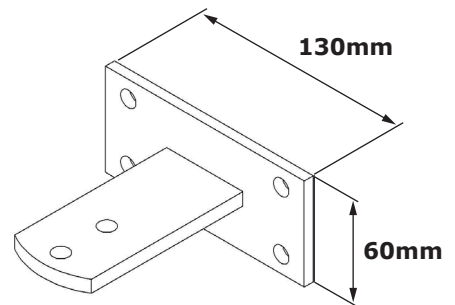

**Rear vertical  
braket**

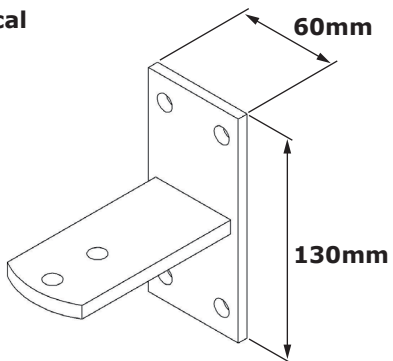

### 3 - BRACKETS INSTALLATION SCHEME

#### 3A - HOW TO USE THE SCHEME

Measure "E" and draw a horizontal line in the scheme (pic.3.3 or 3.4 or 3.5 or 3.6) at the corresponding value.

Choose a point on the drawn line, considering the desired opening angle.

Draw a vertical line from that point and determinate the A value.

Verify that the A value allows the fixing of the rear bracket before continuing the installation, otherwise choose another point on the scheme.

Finally, bring the piston to the limit position (see picture 3.2).

Pay attention: avoid that the sliding pivot touches the aluminium cover.

If the installation measures are not properly followed, the automation may not work correctly. For example:

- Cyclical trends, and sudden accelerations
- Noise of the motor
- Limited opening degree or absent opening (in case of motor counter-lever configuration)

**Pic. 3.1**

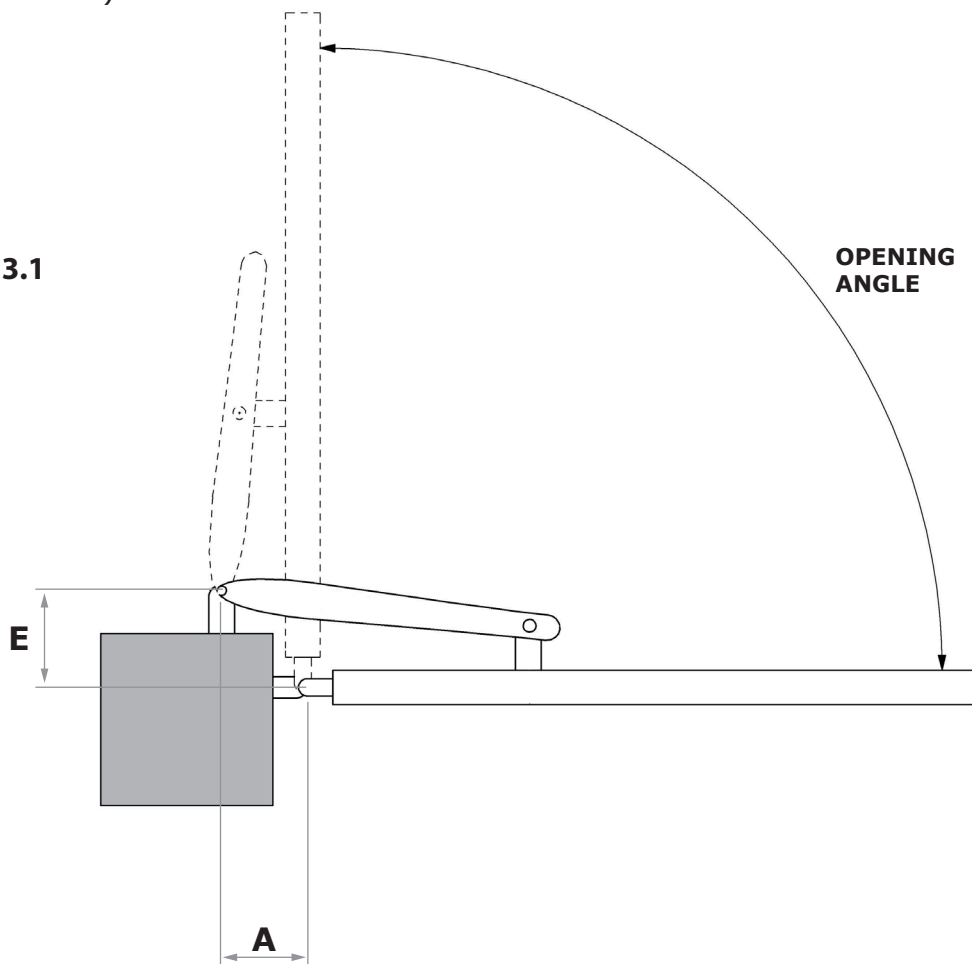

**Pic. 3.2**

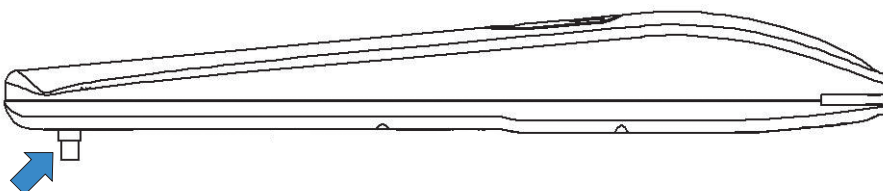

3B - INSTALLATION SCHEME: MECHANICAL LIMIT SWITCH IN OPENING

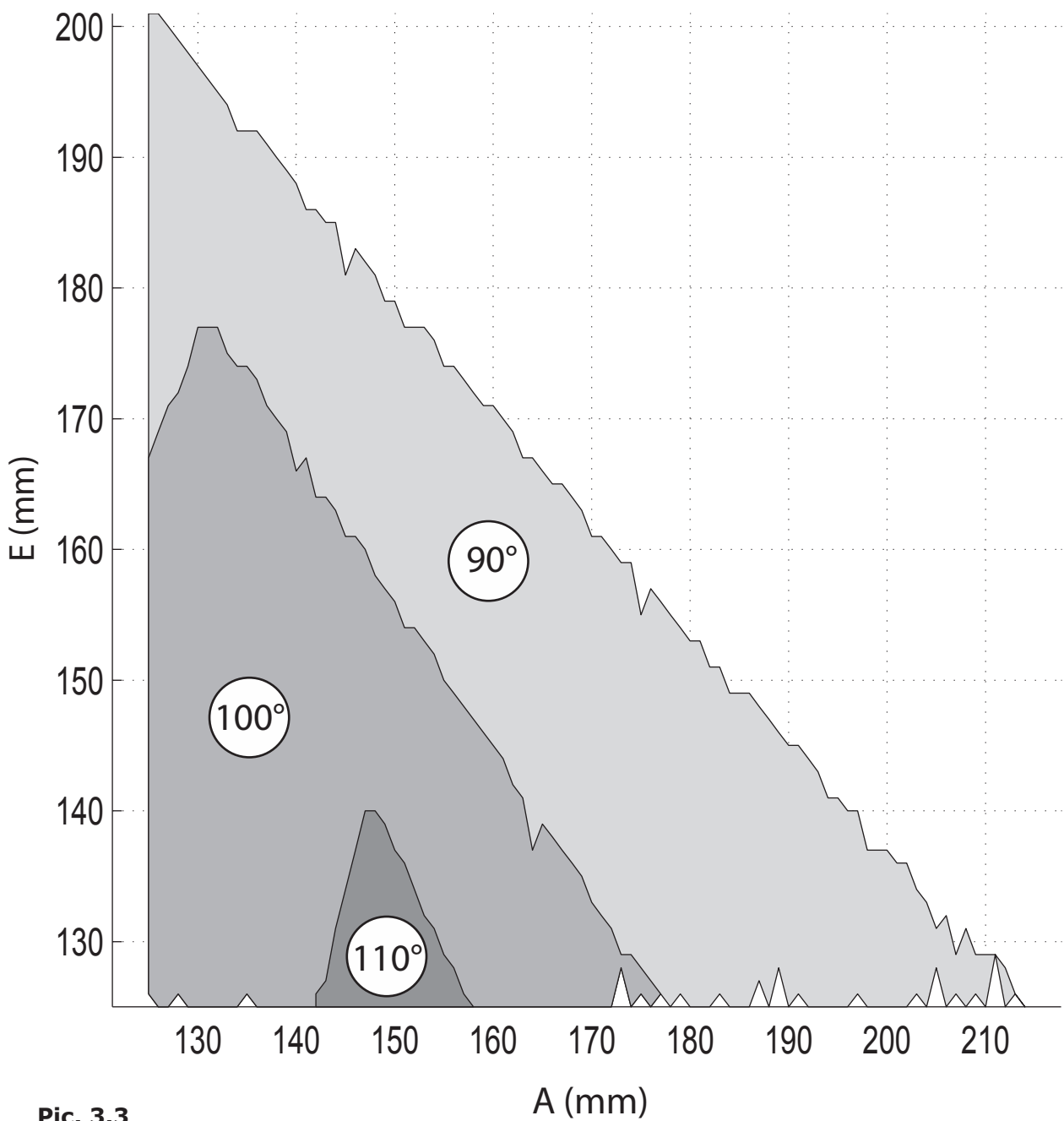
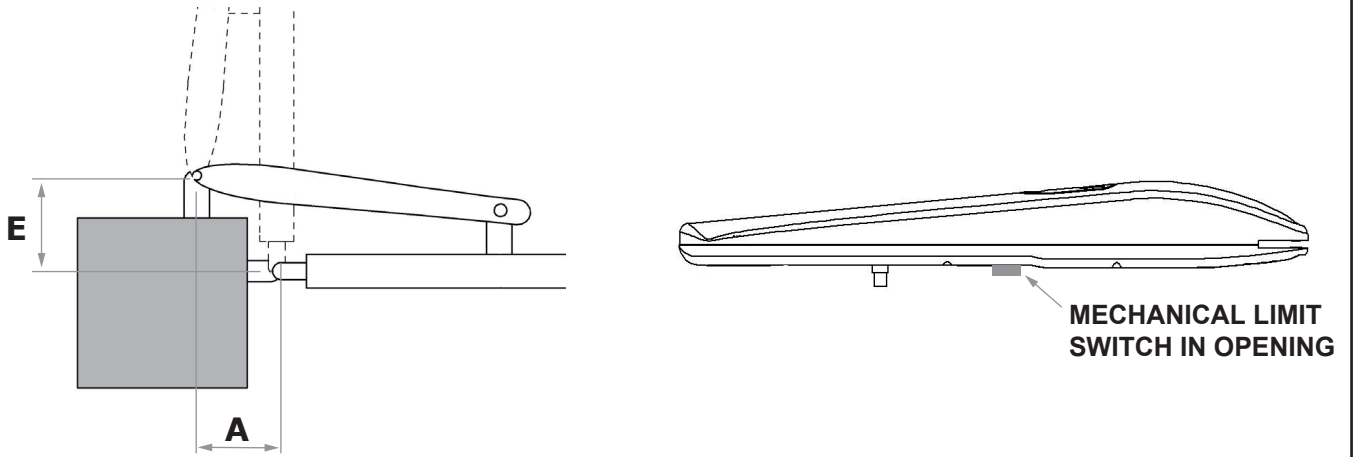

Pic. 3.3

3C - INSTALLATION SCHEME: MECHANICAL LIMIT SWITCH IN CLOSING

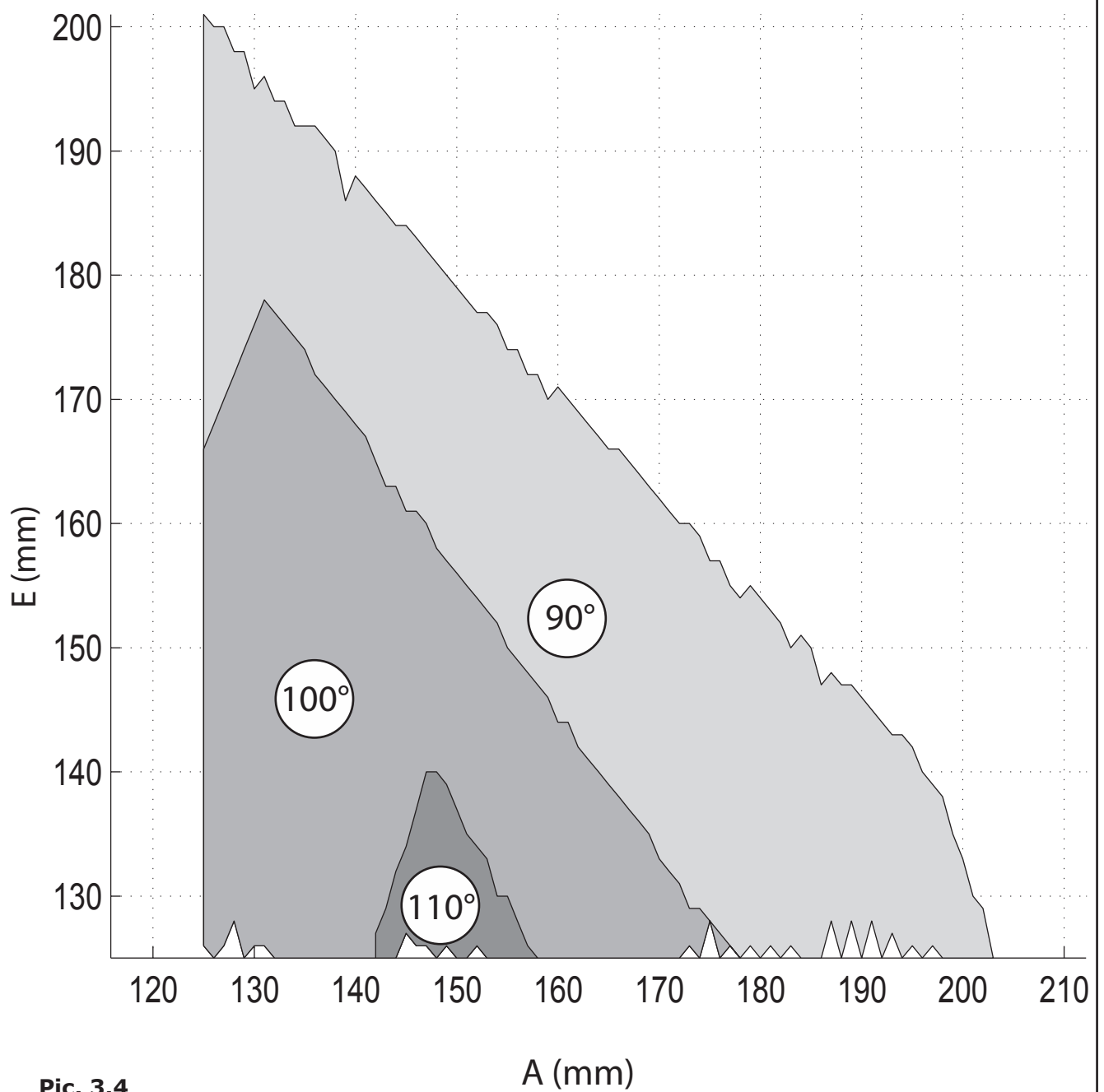
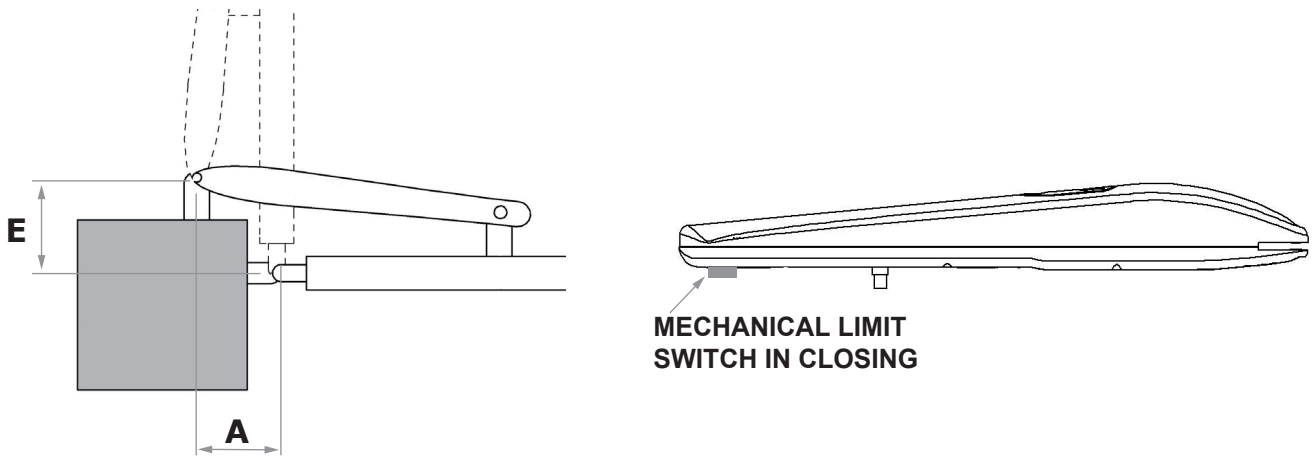

Pic. 3.4

3D - INSTALLATION SCHEME: MECHANICAL STOPS (IN OPENING AND CLOSING, JET TOP VERSION)

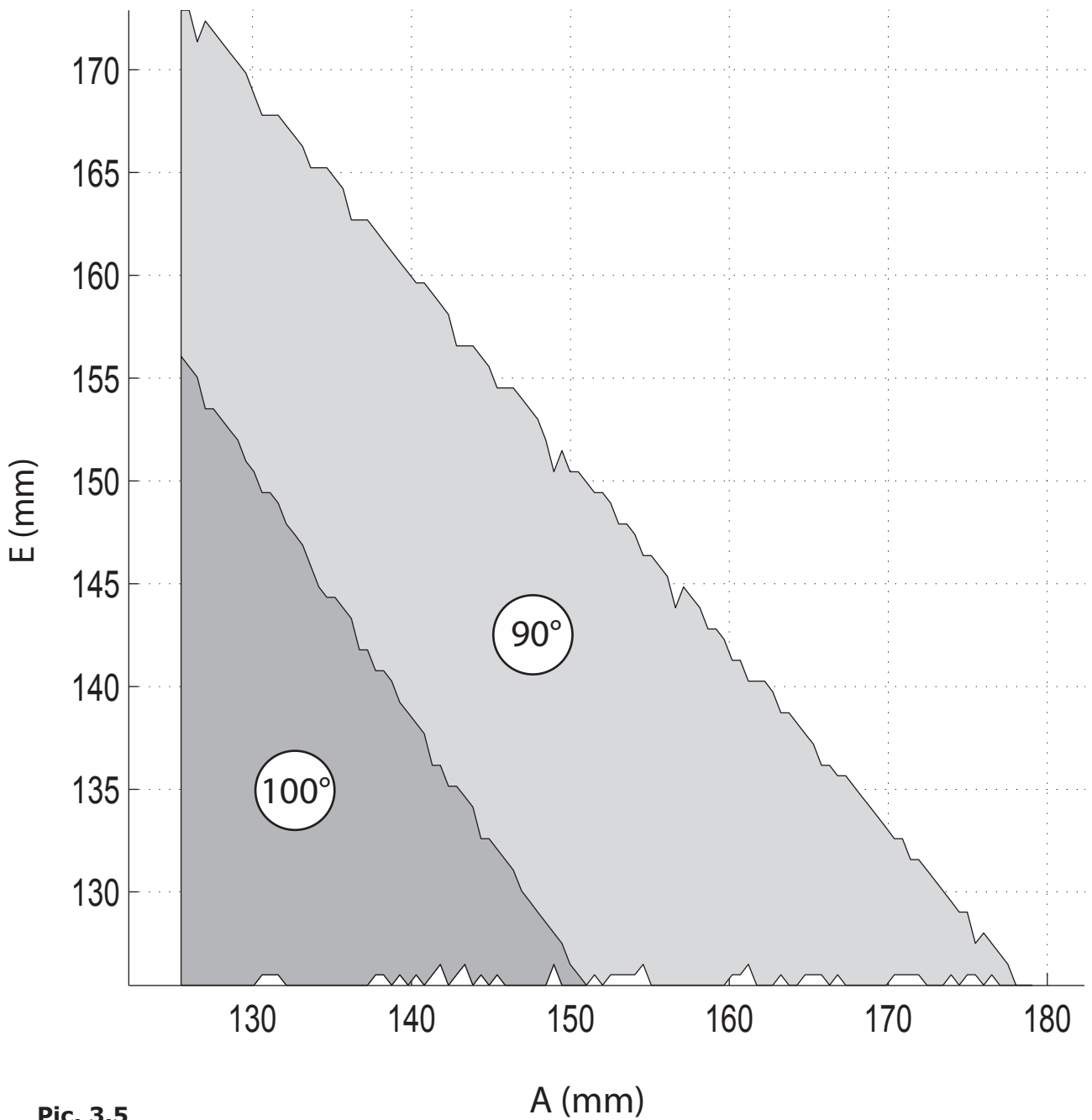
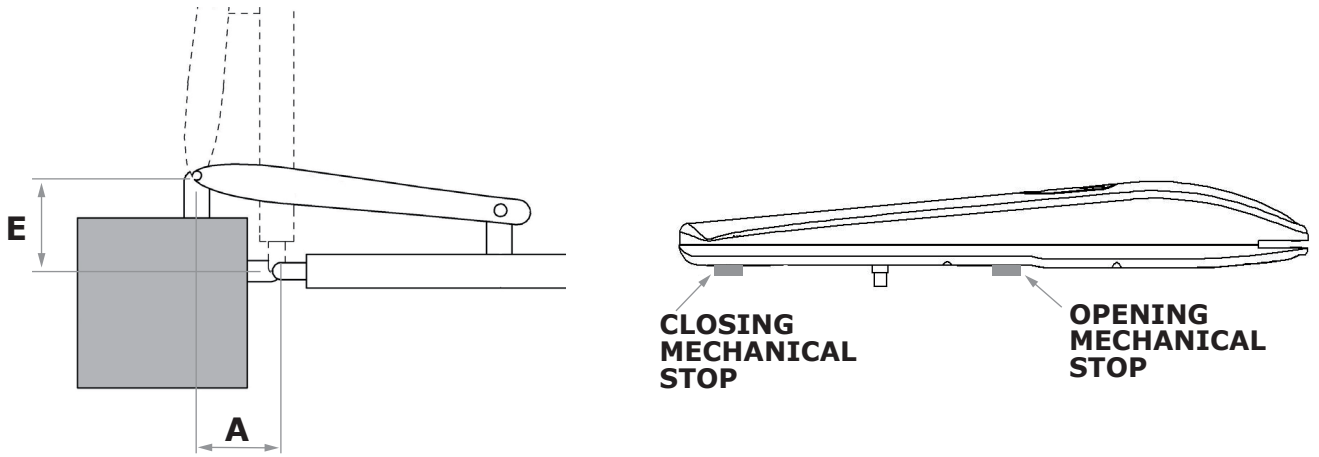

Pic. 3.5



3E - INSTALLATION SCHEME: NO MECHANICAL STOPS

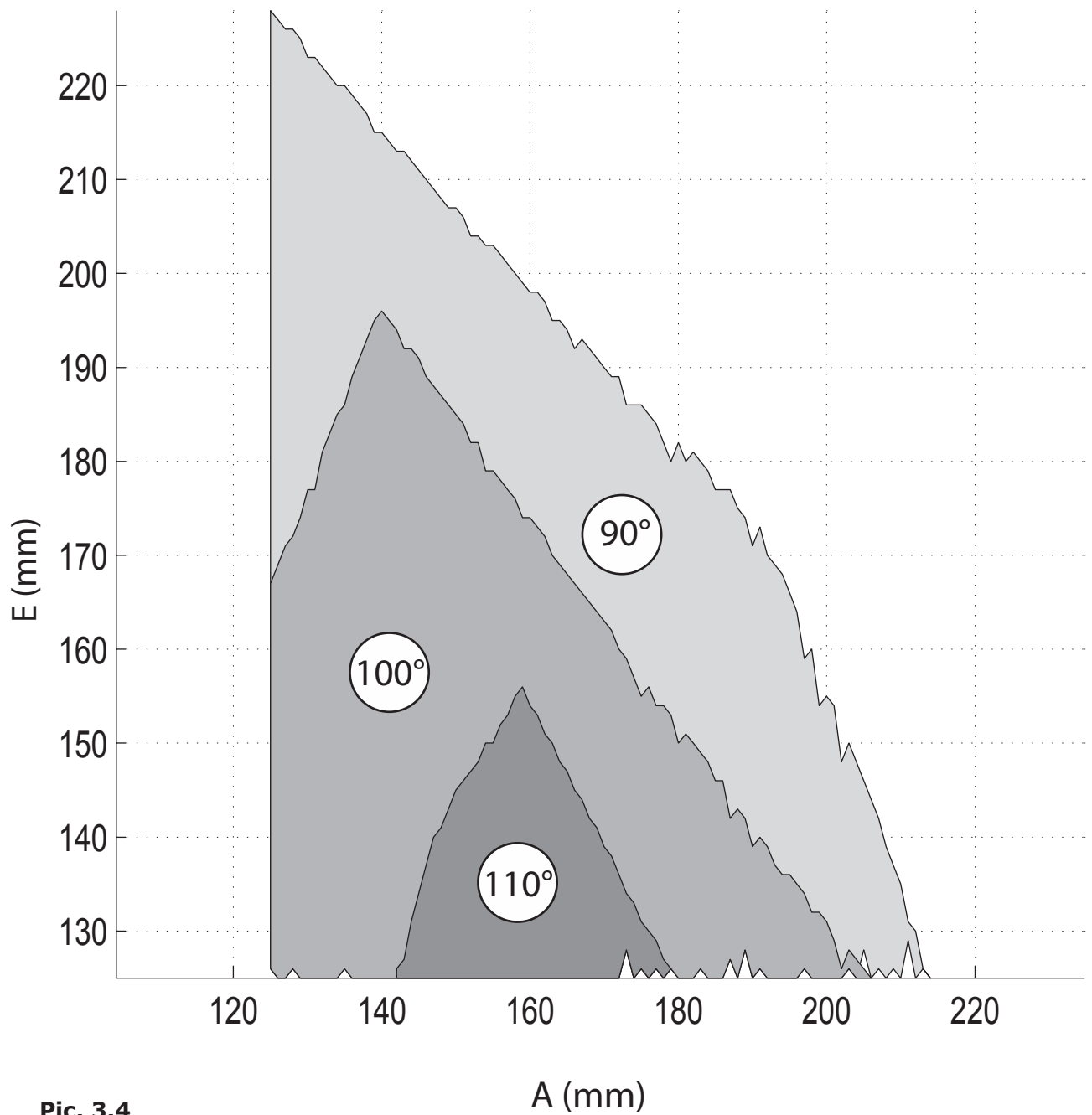
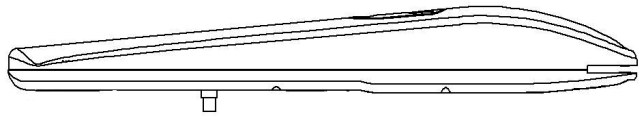
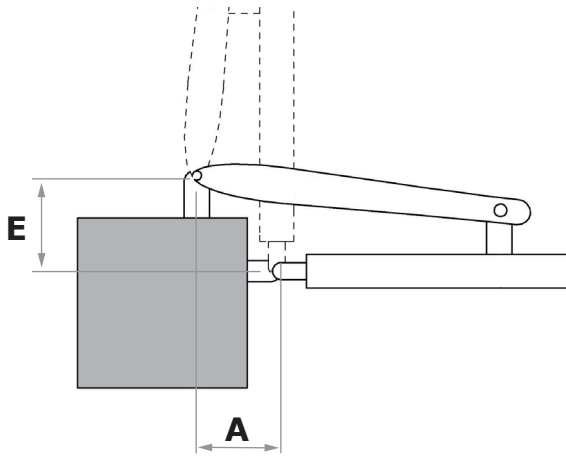

Pic. 3.4

## 4 - INSTALLATION

### 4A - INTRODUCTION

Read the instructions with care before installing the product. The producer disclaims all responsibility for any damage or bad functioning caused by inobservance of the instructions or bad connection that may result in poor safety and functioning of the gear-motor.

### 4B - BRACKETS HEIGHT

Fix the brackets keeping 54 mm between the surfaces in order to fix the gear-motor horizontally. (see pic.1).

1



### 4C - FIXING THE GEAR-MOTOR TO THE BRACKETS

Fixing the gear-motor to the rear brackets. (see pic.2).  
Fixing the gear-motor to the front brackets. (see pic.3).

2

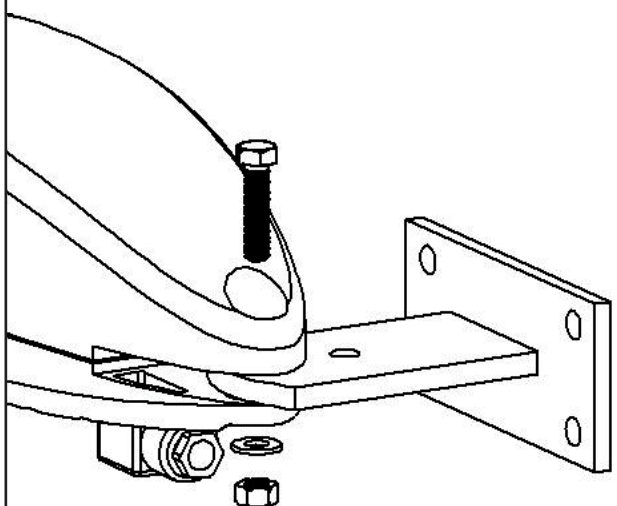

3

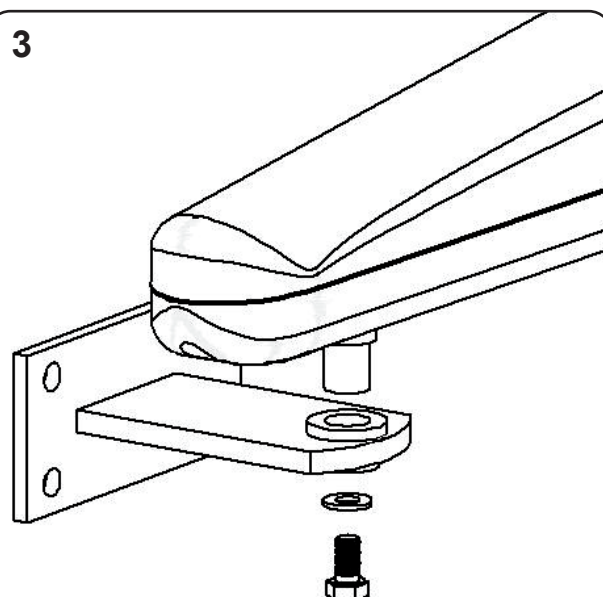

## 5 - MANUAL OVERRIDE

### 5A - INTRODUCTION

⚠ Before operating the manual override disconnect the power

Manual override has been thought for manual opening of the gate in case of power-cut or motor breakdown.

### 5B - OVERRIDE

INSTRUCTION (see pic.4).

- Operate the manual override by moving back the key hole cover.
- Insert the key in the cylinder lock and turn it of 90° clockwise direction.
- Pull the lever till it is perpendicular to the gear-motor.

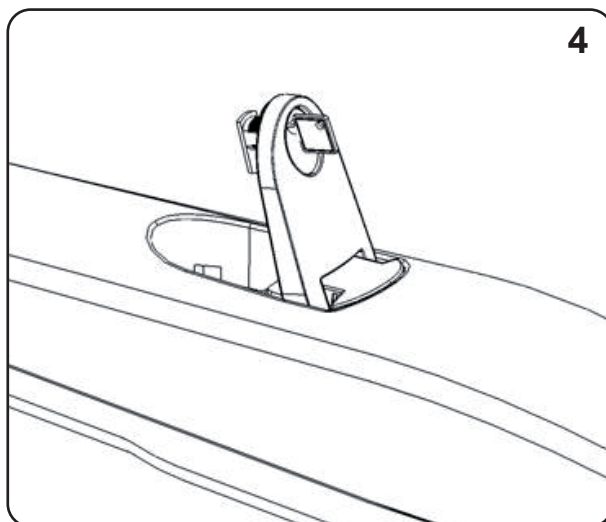

### 5C - RESTORE

INSTRUCTION (see pic.5)

- Bring back the lever in the original position.
- Insert the key in the cylinder lock and turn it of 90° anticlockwise direction.

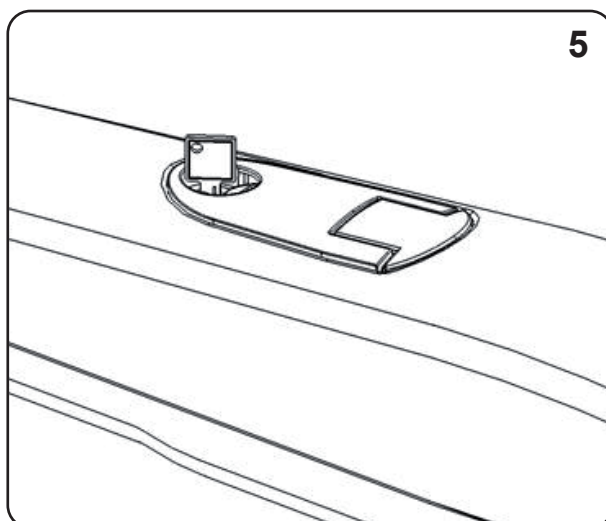

## 6 - ELECTRICAL CONNECTION

### 6A - CONNECTION TO THE POWER STATION

The installer is provided with the assembled connector.  
This has the function of connecting the motor to the power station and to power it.  
This procedure can only be carried out by authorized staff.  
Dismantle the connector by unscrewing screw "A" (see pic.6)

ATTENTION: the electrical connection within the gear-motor is already provided.

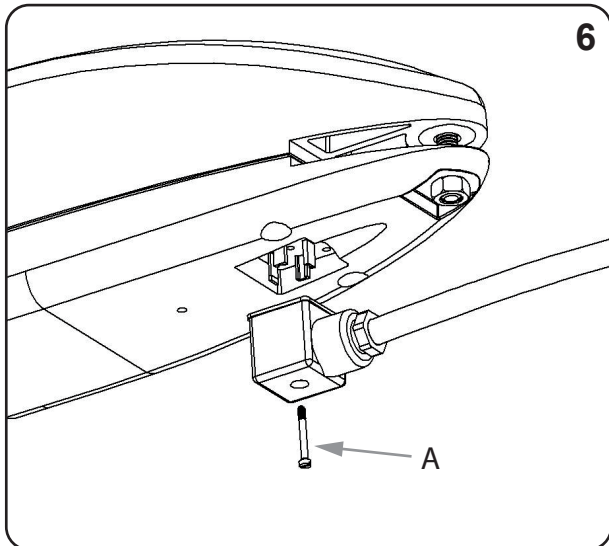

### 6A - CONNECTION TO THE POWER STATION

**JET 230 F**  
**JET 230 S**  
**JET 230 F TOP**  
**JET 230 S TOP**

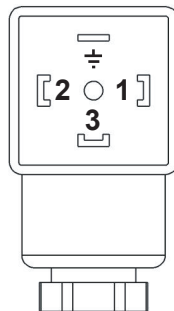

**1 Phase 1**  
**2 Phase 2**  
**3 Common**  
**⊕ Ground**

**JET 24**  
**JET 24 TOP**

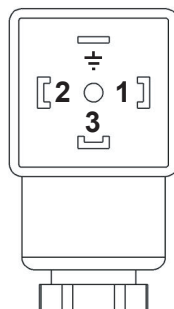

**1 M+**  
**2 M-**  
**3 Not used**  
**⊕ Ground**

## 7 - STOP ADJUSTMENT

### 7A - INTRODUCTION

The mechanical-stop enables to stop the gate at a required position, avoiding the door to hit the stop devices.

### 7B - INSTRUCTION FOR THE REGULATION

INSTRUCTION (see pic.7):

- Set the gear-motor on manual override (pic.4).
- Twist off the screw of the mechanical-stop (B or D).
- Move the door to the desired opening/closing position.
- Place the mechanical-stop next to the sliding pin (C).
- Turn the screw tightly.
- Set the gear-motor on automatic functioning (pic.5).

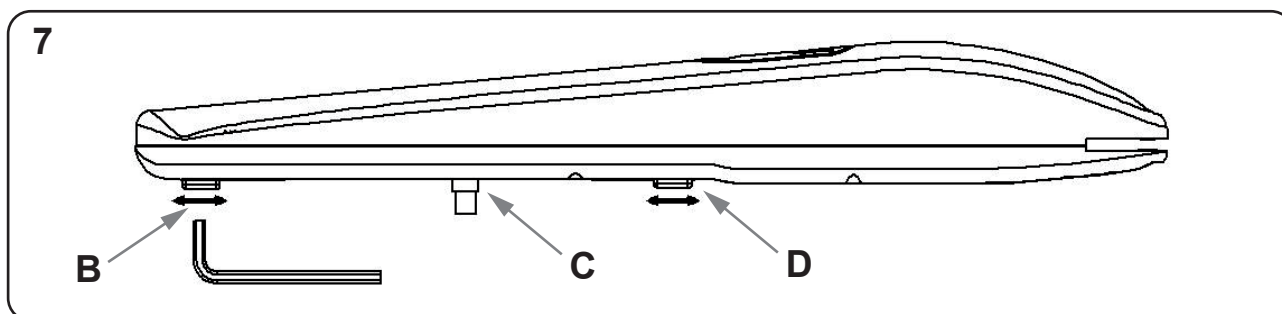

⚠ The gear-motors are normally provided with mechanical stop in open position. In case of lack of external mechanical stop in closing position, it is possible to buy the optional mechanical stop.

# DICHIARAZIONE CE DI CONFORMITÀ

## DECLARATION OF CONFORMITY

Il sottoscritto Alex Antonioli, legale rappresentante della ditta King gates srl, dichiara che il prodotto:

*The undersigned Alex Antonioli, general manager of the following producer, declares that the product:*

NOME PRODUTTORE: King gates srl  
*Manufacturer's name:*

INDIRIZZO: Via A. Malignani 42, 33077 Sacile (PN) Italy  
*Address:*

TIPO: Attuatore elettromeccanico per cancelli a battenti  
*Type: Electromechanical gearmotor for swing gates*

MODELLO: Jet 230 F, Jet 230 S, Jet 24  
*Model: Jet 230 F Top, Jet 230 S Top, Jet 24 Top*

Risulta conforme a quanto previsto dalle seguenti direttive europee:  
*Satisfies the essential requirements of the following Directives:*

### DIRETTIVA BASSA TENSIONE

*Low Voltage Directive*

2006/95/CE

EN60335-1

EN60335-2-103

### DIRETTIVA MACCHINE

*Machinery Directive*

2006/42/CE

### COMPATIBILITÀ ELETTROMAGNETICA

*Electromagnetic Compatibility*

2004/108/EC, 92/31/EEC, 93/68/EEC, 91/263/EEC

EN61000-6-1

EN61000-6-3

Come previsto dalla direttiva 2006/42/CE si avverte che non è consentita la messa in servizio del prodotto sopra indicato finché la macchina, in cui il prodotto è incorporato, non sia stata identificata e dichiarata conforme alla direttiva 2006/42/CE.

*As specified in the directive 2006/42/CE use of the product specified above is not admitted until the machine on which it is mounted has been identified and declared as conforming to the directive 2006/42/CE.*

Sacile, 05 Settembre 2011  
*Sacile, 05 September 2011*

Il legale rappresentante  
*Managing Director*  
Alex Antonioli





## INSTALLER REFERENCE

COMPANY:

PLACE:

PROVINCE:

TELEPHONE NUMBER:

CONTACT PERSON:

STAMP

## PRODUCER REFERENCE

# KINGGates

**King Gates S.r.l.**

Via A. Malignani, 42 - 33077 Sacile (PN) ITALY

Tel. +39 0434 737082 - Fax +39 0434 786031

e-mail: [info@king-gates.com](mailto:info@king-gates.com) web: [www.king-gates.com](http://www.king-gates.com)